

Use of Digital Twins within the Rail Industry

Technical report





Synopsis

The paper investigates the role of Digital Twins in the railway industry, with a specific focus on how to make these sophisticated tools widely accessible for practical, everyday applications.

The benefits gained by integrating VampirePro® software, known for its proven pedigree, into the existing DigitalTrains™ environment are highlighted. Issues such as bogie behaviour, wheel-to-rail interactions, and track irregularities are discussed.

The paper provides case studies, including the creation of virtual railway routes and analysis of train behaviour on curved tracks.

The paper emphasises that, when made accessible, Digital Twins can offer invaluable insights into the complex challenges in the railway industry.

Introduction

DigitalTrains™ is a Digital Twin environment. The virtual trains and sub-assemblies within DigitalTrains™ along with the track and infrastructure are true Digital Twins of the physical equivalent. They are geometrically correct and perform as the physical counterpart would perform.

It is referred to as a Digital Twin environment because it's not only where the 'twins' reside, but the platform consists of all the tools required to create them, bring them to 'life' and sustain them.

It is well understood that the earlier in the process, the design is finalised the lower the cost of the project. Creating a Digital Twin of the 'system' in the early stages of the project can significantly reduce the lead time of the project by getting the design 'right first time' and avoiding costly late design modifications. In this context the 'system' refers to the train, track and infrastructure.

It is not only in the development phase that Digital Twins are useful, but they can and should be utilised throughout the life of the train or infrastructure.

The purpose of Digital Twins in the rail Industry

- **Reduce project lead times and save money**
- **Maximise safety**
- **Provide accurate simulations under many scenarios**
- **Understand trains performance long before the train is built**

What would the Ideal Digital Twin Environment look like?

Ease of use to Optimise efficiency

For the Digital Twins to be fully utilised they need to be available to as many people as possible. Whilst expert knowledge may be required to create the models, once created they need to be accessible to a broad spectrum of users, wherever they may be. Their use needs to be a matter of course rather than the exception.

Treats the railway and its network as a single system

The railway is a system consisting of trains, track and infrastructure. The system needs to be treated as a whole. The Digital Twins need to be available for a wide range of analysis, these may include studying wheel to rail interaction, gauging or the crash energy management of a train.

Advanced fast and accurate simulation tools

DigitalTrains™ incorporates VampirePro®, a railway dedicated multi-body simulation package originally developed in the UK by British Rail Research in the 1970s. VampirePro® has been validated against real life tests and some details of these are given later.

DigitalTrains™ also incorporates Oleo International's crash energy management software, which has also been validated against real life tests. All the crash energy components available in DigitalTrains™ have been validated in accordance with EN15227 in an ISO17025 accredited laboratory

Instant global collaboration with all stakeholders

DigitalTrains™ operates online, enabling seamless interconnectivity among all users. The platform features specialised corporate areas, also known as

libraries, where companies can store and share their digital models. These libraries are equipped with administration tools that grant administrators control over both the content and access permissions. Additionally, there are tools designed for setting up and managing project libraries. These project libraries can exist either within individual organisations or span across multiple organisations.

Help users understand and interpret analysis results

Ensuring that Digital Twins are accessible to non-experts necessitates particular emphasis on interpreting the results. The objective is to make the results of any analysis as clear as possible

Using a suite of tools designed for this purpose users can view and compare analysis outcomes. The system can auto-generate reports that highlight any anomalies or unusual results.

Support from rail engineers and software professionals

DigitalTrains™ has extensive online documentation and video tutorials. An online service option is also available to help you create your own Digital Twins. Our team of professional engineers and software developers are always looking for new ways to improve the user experience.

There are many aspects to Digital Twins, too many for a single publication. We will focus on a few applications to demonstrate the advantages of using a Digital Twin environment over more conventional standalone software.



1.0 Mapping and Defining Track Conditions

Before conducting any analysis on a rail system, it is essential to define the track layout over which the trains will operate and to position the surrounding infrastructure. Within the DigitalTrains™ platform, these track layouts are termed as "route profiles."

Comprising both vertical and horizontal geometrical profiles, including transition curves and super elevation (also known as cant). The example is based on survey data from a segment of the HS2 high-speed rail line, currently under construction in the UK.

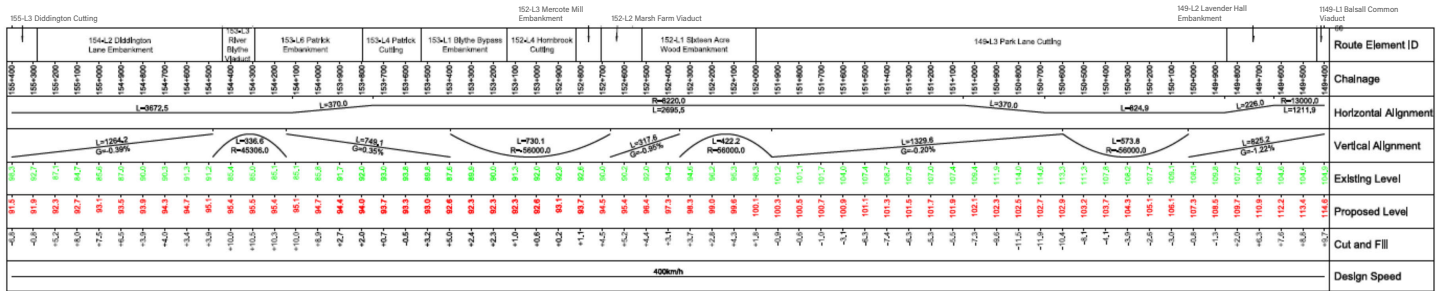

Figure 1.1 Typical railway survey data (example for HS2)

The data describes both a horizontal and vertical profiles. The horizontal profile is described by defining the length of a straight or curved track along with its radius, and the length of the transitions into or out of

the curve. It is easy to enter this data directly into DigitalTrains™ since the data is presented in a similar format.

The route is defined in discrete section lengths which are either straights, constant curves, or transition curves.

Distance at Section(m)	Section Length(m)	Radius(m)	CANT(mm)		
0	0	-	0		Transition To Straight
0	3672.5	-	0		Straight
3672.5	370	8820	0		Transition to Left Curve
4042.5	2695.5	8820	0		Curve Left
6738	370	-	0		Transition To Straight
7108	824.9	-	0		Straight
7932.9	226	13000	0		Transition to Left Curve
8158.9	1211.9	13000	0		Curve Left
Total Distance					
9370.80					

Figure 1.2 Survey data entered into DigitalTrains

The transition curves within the horizontal profiles are modeled using Euler spirals, wherein the curvature varies linearly along the length of the curve.

The vertical profile is similarly defined except the transitions are all radii.

The transitions and cant, can be computed for the track's design speed using the platform's integrated cant calculator. The calculated cant is determined based on the track curvature, the length of the

transition zone and the rate at which the cant changes, subject to a maximum specified value. Alternatively, the cant values can be entered manually.

CANT Calculator

Transition Type <input type="text" value="Euler Spiral"/>	CANT Type <input type="text" value="Raising Center of Gravity of Train"/>
Final Radius (m) <input type="text" value="1247"/>	<input type="checkbox"/> Set a specific gradient
Max Speed (km/h) <input type="text" value="50"/>	CANT Gradient (mm/m) <input type="text" value="2.778"/>
Track Gauge (mm) <input type="text" value="1435"/>	CANT Rate (mm/s) <input type="text" value="CANT Rate (mm/s)"/>
Required CANT (mm) <input type="text" value="Required CANT (mm)"/>	Transition In <input type="text" value="Transition In"/>
	Transition Out <input type="text" value="Transition Out"/>
<input type="button" value="✓ INSERT TRANSITION"/> <input type="button" value="+ CALCULATE TRANSITION CURVE"/>	

Figure 1.3 Transition curve and super elevation calculator

The route profile can be reviewed on a map by specifying the start locations longitude, latitude an heading.

This example demonstrates one of the mapping options available within the DigitalTrains™ platform. Other methods for data input include interactive data entry directly onto an online map or the capability to upload GPS-derived data.

Regardless of the method employed to generate the route profile, the system allows for the overlay of track irregularities onto the defined route.

These irregularities are variations in the track profile, manifesting as localised perturbations around the track's nominal positions.

Such variations may include the lateral and vertical positioning between the left and right rails. If measured values are available for a specific track, they can readily be uploaded.

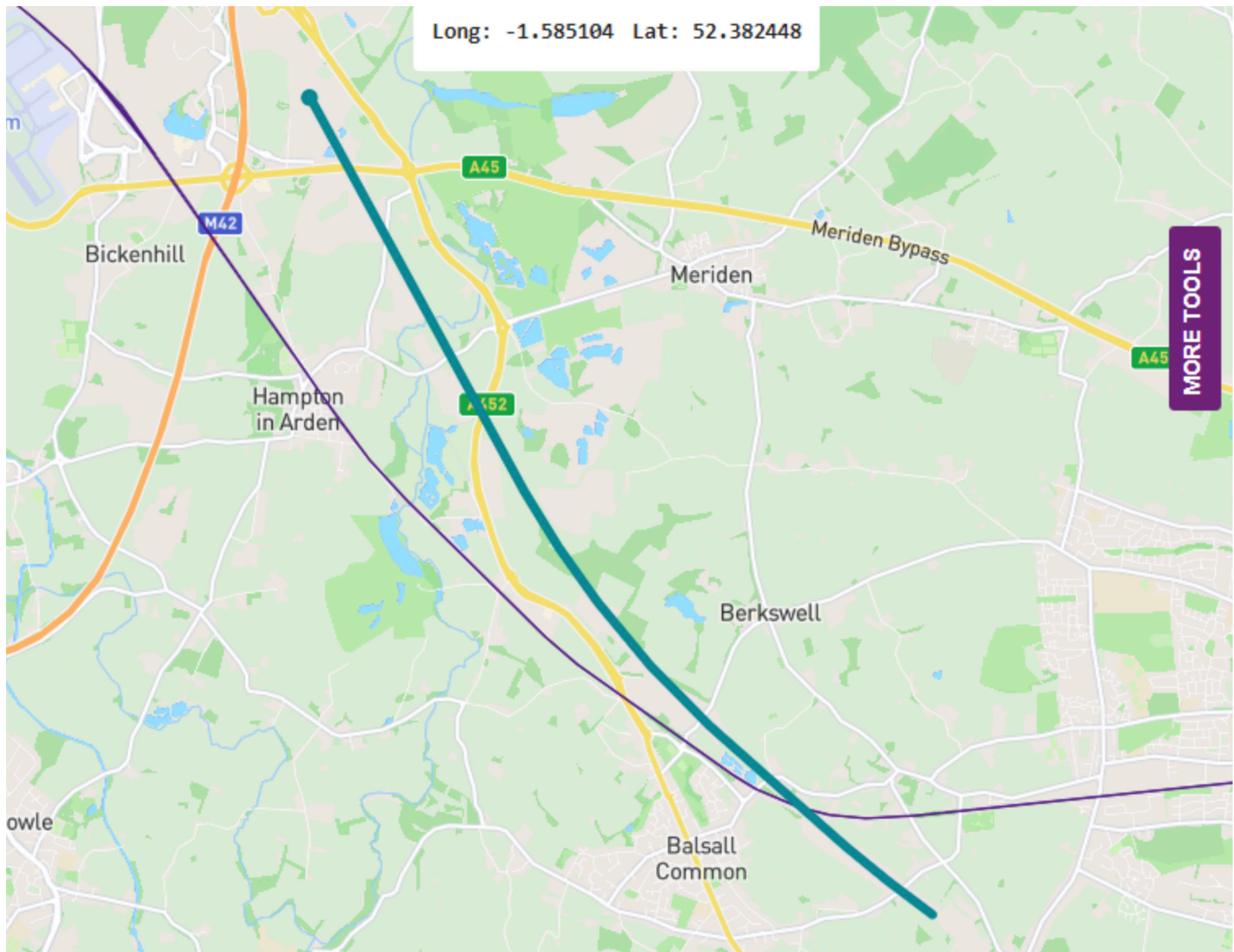

Figure 1.4 View of route profile on a map

Alternatively, the DigitalTrains™ libraries retain access to standard files originally included in the VampirePro® software. These files consist of five segments of standard measured straight track, multiple AAR test tracks conforming to Chapter XI specifications, and three specialised track files intended for specific applications

Once the route profile has been configured, any train stored in the DigitalTrains™ library can be simulated

traversing the specified route. All the analytical tools from VampirePro®, used to verify the train's performance, are integrated into the DigitalTrains™ platform.

For those not familiar with VampirePro®, a brief overview of some of the features are explained overleaf:

1.1 Passenger Comfort Calculations

DigitalTrains™ retains all VampirePro® filters, including those explicitly designed for the computation of ride and comfort indices. This integrated functionality allows users to verify in advance whether the rolling stock will comply with established standards for ride comfort, prior to the actual construction of the train.

Such proactive verification substantially mitigates the financial risk associated with post-delivery modifications. To attain this level of validation, users may be required to conduct a series of simulations, each utilising varying suspension parameters and spanning extensive track lengths.

1.2 Track Quality Processing

The fast simulation capabilities of DigitalTrains™ enables the processing of large quantities of track data, allowing for maintenance strategies to be formulated based on vehicle response rather than solely on track geometry. The ability to simulate any of

the trains in the library over any measured track, can give an indication of derailment risk, passenger comfort, required speed restrictions etc. aiming to identify and prevent potential issues before they occur.

1.3 Derailment Investigations

Simulating derailment is a severe test of the software's accuracy. VampirePro® is extensively used in the UK to simulate the reconstruction of dynamic derailment. Simulating derailment is strongly dependent on conditions such as wheel/rail friction levels and the wheel and rail profiles. When designing for safety in the early stages of a project, the approach of setting limits on the value of Y/Q is recommended, rather than designing to the actual derailment point.

A positive Y/Q value signifies that the wheel is exerting pressure against the flange in the direction conducive to derailment. The associated risk is a function of both the magnitude and the duration of peak Y/Q values. A typical acceptance criterion might stipulate a Y/Q value of 1.2, sustained for a duration of 50 milliseconds. The Y/Q metric serves as a gauge for assessing the proximity of a vehicle to a potential derailment scenario; therefore, limits should be established to ensure an adequate safety margin.

All wheel analysis features available in VampirePro® are retained in DigitalTrains™, including the derailment indicator Y/Q, also known as L/V. This ratio quantifies the relationship between the lateral and vertical loads exerted on a wheel and serves as an indicator for assessing the risk of flange-climbing derailment.

In addition DigitalTrains™ incorporates supplementary functionalities specifically designed for simulating train operations along a defined route profile.

1.4 Traction and Braking

DigitalTrains™ enables users to insert 'markers' at any location within the route profile. These markers designate specific points where events, such as brake application or acceleration, occur. The platform includes libraries for both braking and traction characteristics, as well as tools to define these

variables as functions of time, distance traveled, or vehicle velocity. By monitoring the train's traction effort over a specific route, the energy consumption can be analysed and its correlation with the train's velocity profile can be assessed.

1.5 Clearance Analysis

DigitalTrains™ is equipped with a clearance calculation feature that assesses the spatial relationship between a train, or more specifically a train's gauge, traveling on a specified route and structural gauges placed along the route. The software includes libraries for both vehicle and structural gauges, as well as utilities to customise them.

Users have the flexibility to associate any vehicle gauge with any train model in the libraries, and to position structural gauges at any location along the track. The clearance calculator automatically identifies sections where the clearance falls below predetermined thresholds, facilitating detailed analysis of these areas.

2.0 Side Buffer Head Overlap Through a 'S' Curve

This example outlines an analysis conducted to evaluate the potential risks associated with the interaction of side buffer heads as a train navigated a 'S'-shaped curve in the track. Initial concerns arose from a kinematic simulation, which indicated that any additional lateral movement in the bogie could result in the buffer heads disengaging and interlocking.

To investigate these concerns, a 3D simulation was deemed necessary. This simulation encompassed modelling of the bogie's suspension system,

wheel-rail interactions, and precise geometric movements of the buffer head.

The initial step entailed constructing a three-piece bogie using DigitalTrains' Bogie Builder feature. This tool is similar to VampirePro's Train Builder and includes all the original VampirePro® suspension elements. However, due to its online platform, the user interface has been modernised to give a more intuitive user experience.

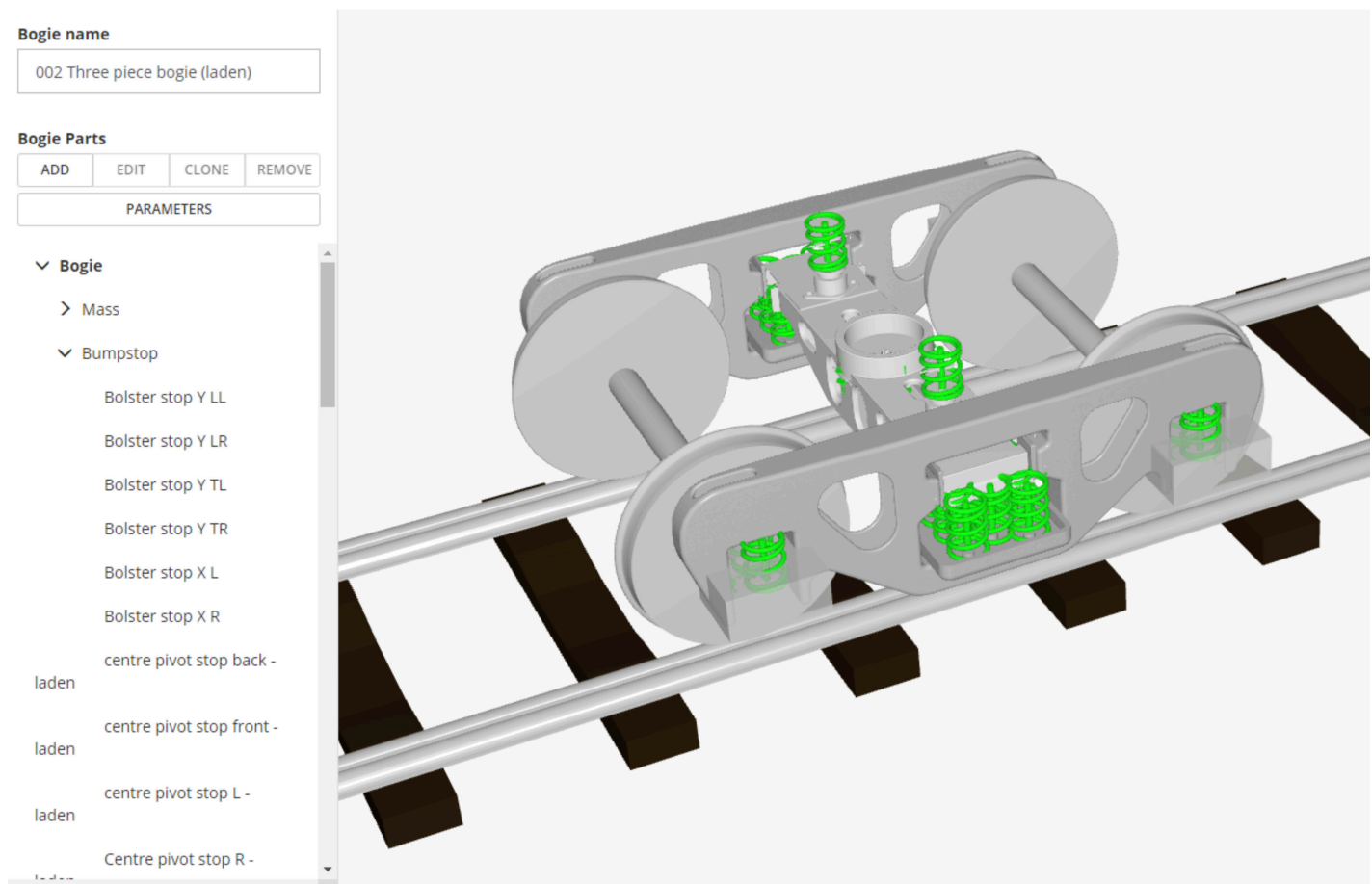

Figure 2.1 Snapshot of DigitalTrains™ Bogie builder

In DigitalTrains™ the vehicles have their own separate vehicle body library and tools to define the geometry and mass condition of the vehicle body.

This is because the geometry of the vehicle bodies, particularly at the vehicle ends, is important when

simulating longitudinal train dynamics and crash energy management.

For this analysis we restricted the number of vehicles to three, the final model had 186 degrees of freedom.

Model Composition

Mass elements	21
Wheelset elements	12
Friction elements	180
Bumpstop elements	288
Bush elements	6
DEGREES OF FREEDOM	186

The vehicles body geometry was defined as follows:

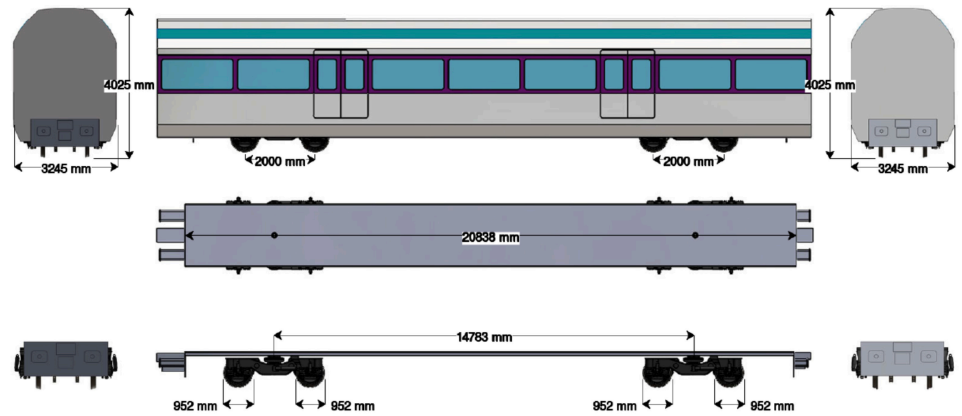

Figure 2.2 Vehicle geometry

The train was simulated traversing a UIC defined 'S' curve 150m-6m-150m. Two different graphs were used to explain the results. The first was a plot of the buffer head overlap against time for the interface between the leading and second vehicle, which showed that the minimum overlap was 38mm.

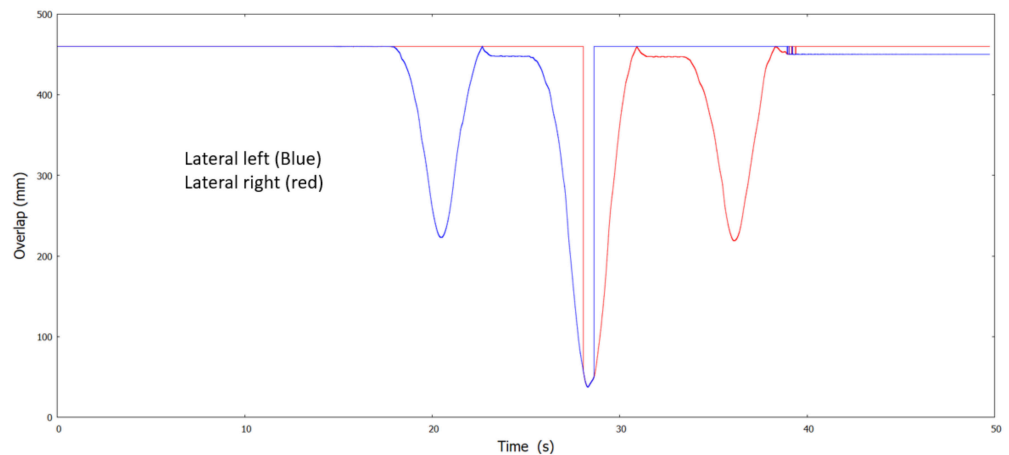

Figure 2.3 Buffer heads overlap against time

While the graph directly addresses the initial question regarding buffer overlap, it provides limited insight into the underlying mechanism responsible for the result. Additionally, the method for expressing overlap when the buffer heads are not in contact is unclear. For this reason, the graph represents the overlap as the diameter of the buffer heads, when the heads are not in contact, which in this case is 460mm.

Head lateral contact displacement

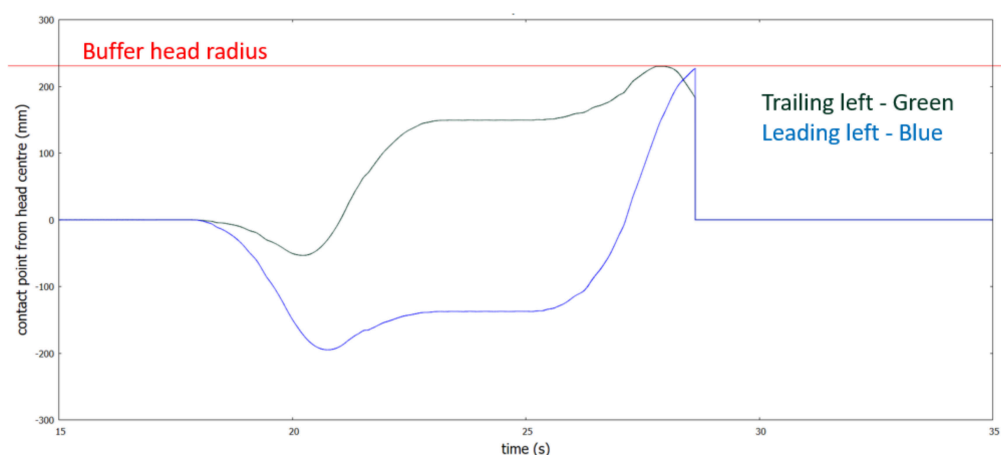

Figure 2.4 Lateral displacement of contact between buffer heads

The second plot shows the lateral movement of the contact point between the buffer heads against time. This graph reverted to zero when the buffer heads were not in contact.

The graph (on previous page) depicts the contact points between the two buffer heads on the left-hand side of both the leading and trailing vehicles. Initially, both buffer heads have a contact point of zero, indicating that the contact point is at the centre of each buffer head when the track is straight and level. The outer limit of the buffer heads is marked in red, representing the radius of each buffer head.

While the graph doesn't immediately clarify the minimum overlap between the buffer heads, it provides more insight into the underlying mechanisms. The graph indicates that both buffer heads approach their respective outer limits but not simultaneously.

The result is easier to understand visually, since it can be seen how close the buffer heads come to exceeding their width.

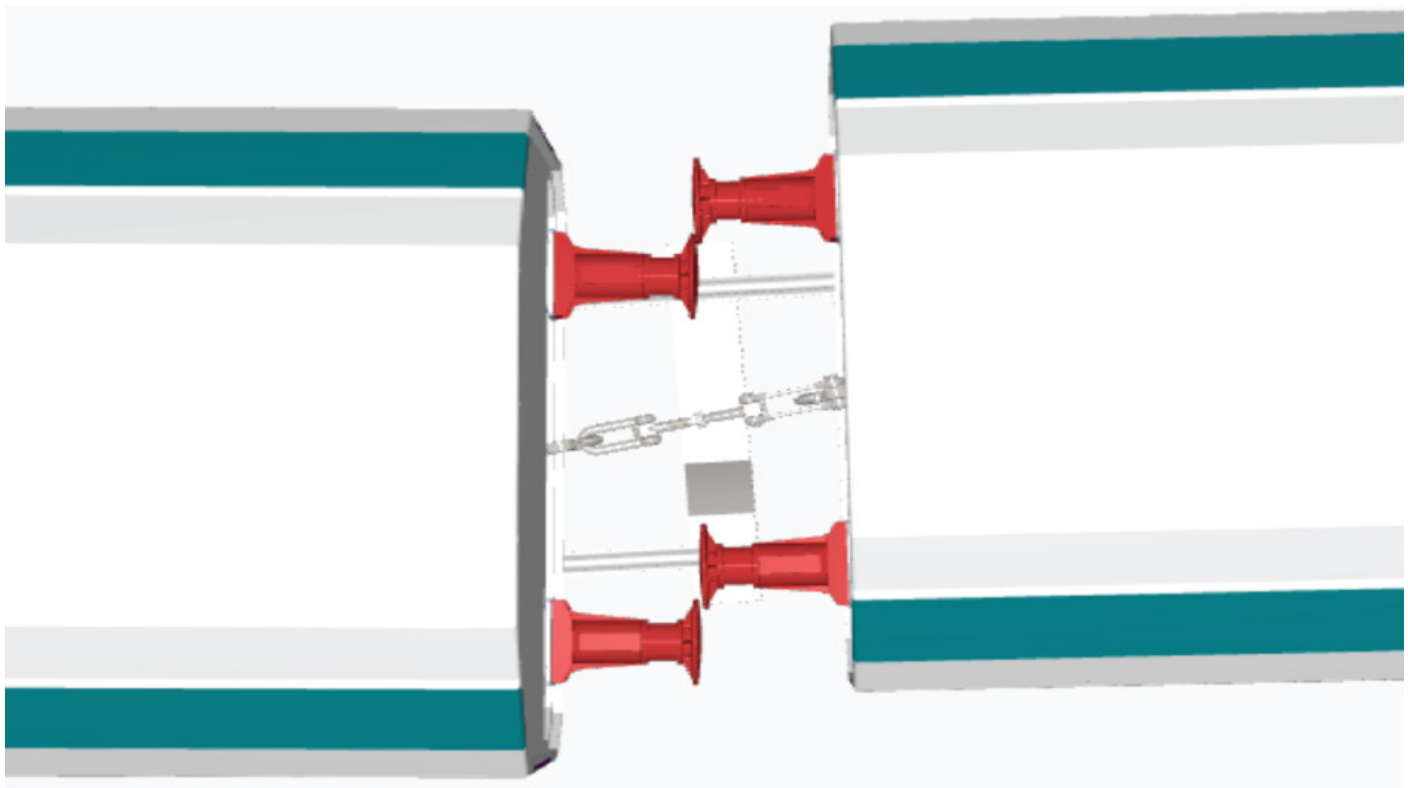

Figure 2.5 Extreme overlap of buffer head

This simulation serves as an example where animation is most effective for conveying complex information, even to non-experts. DigitalTrains™ offers the option to present investigation results through its Open Viewer, which is free to access.

This streamlined process eliminates the need for the analyst to spend extensive time writing reports to explain the findings. The Open Viewer can be freely shared with other interested parties.

The Open View provides several advantages

1. Allows the client to easily grasp the animation.
2. Enables the client to view any of the graphical outputs available.
3. Offers an option to download an auto-generated report summarising the simulation results.

3.0 Impacts on Curves

The next example explores the impact dynamics on a curved track. Traditionally, crash energy management and coupling/shunting acceptance criteria have been analysed on straight, level tracks.

While DigitalTrains™ has always possessed kinematic simulation capabilities for curved collisions, the integration of VampirePro®'s wheel-to-rail simulations now enables comprehensive three-dimensional analyses. This permits evaluations of how the crash energy management of a train is influenced by impacts on curves and the associated derailment risks.

To demonstrate this capability, two examples are presented. The first is a freight train equipped with side

buffers, and the second is a passenger train fitted with centre couplers and anti-climbers. It is not anticipated that the energy absorption capacity of a centre coupler would be significantly affected by an impact occurring on a curve. However, the performance of side-mounted devices such as anti-climbers or side buffers could be notably influenced, as a single side device will initially be engaged, whereas in a collision on a straight, both side devices would engage simultaneously.

The influence on the stability of the train is expected to be more pronounced if significant offset loads are applied.

3.1 Curve Profile

The same curve track was used for both examples given in this section. To illustrate the issues, we simulated a tight curve radius of 200m and applied super elevation of 140mm.

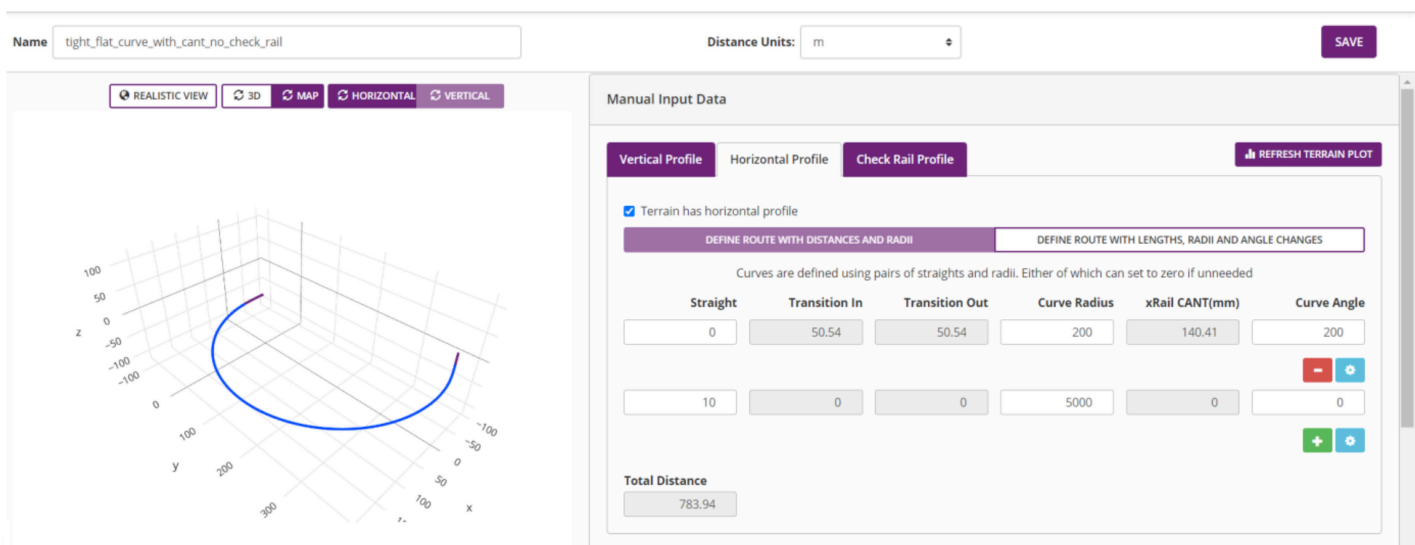

Figure 3.1 Curve Definition

3.2 Freight Train Impacting on a Curve

A freight train consisting of a 90T locomotive and three 90T freight wagons, all equipped with 'Y25' freight bogies, was simulated.

The vehicles were connected by 12kJ drawgears and EN15551 category C hydraulic side buffers.

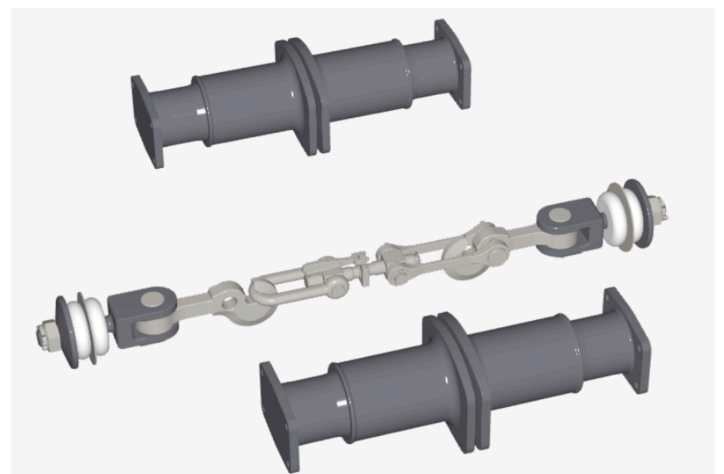

Figure 3.2 Freight Train Coupling

The two train sets were impacted at 11km/h. At the collision interface between the two locomotives, the side buffers on the inside of the track make contact significantly before the buffers near the outer track, they also experience greater displacement or "stroke".

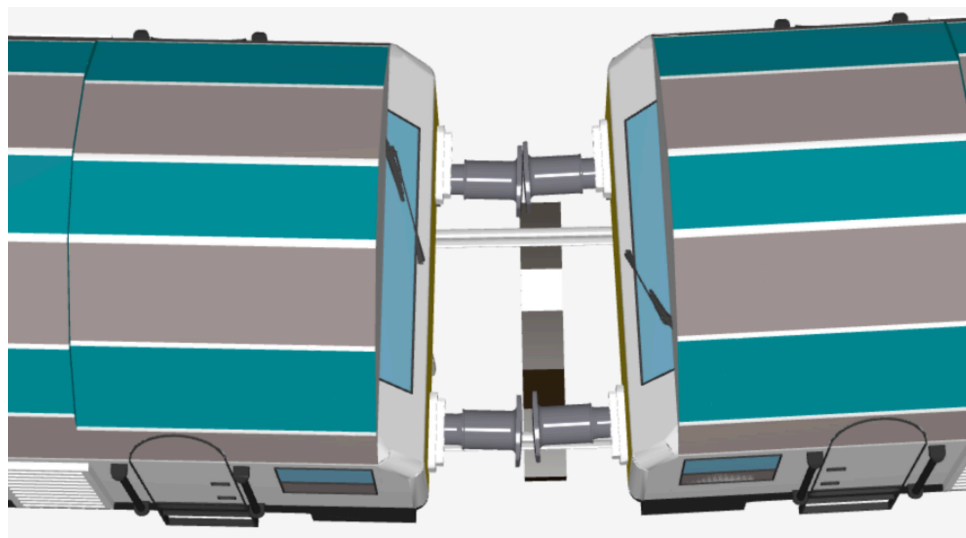
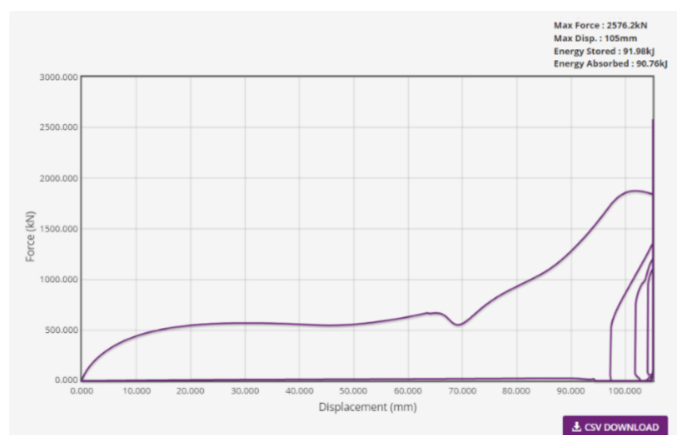

Figure 3.3 Geometry of train at point of impact

The respective force-stroke diagrams at the impact interface are given below:

Buffers on inside of track



Buffers on outside of track

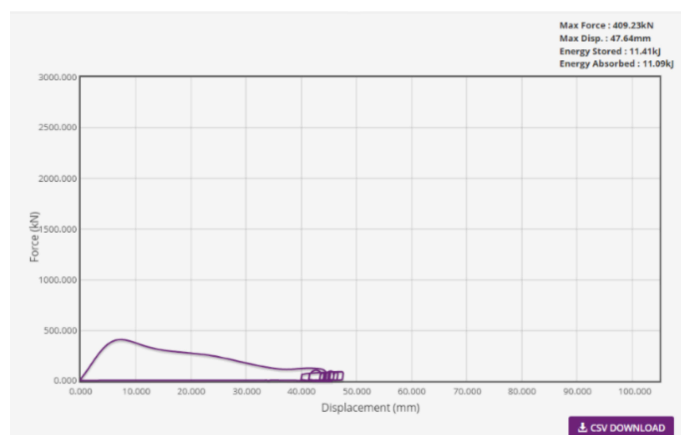

Figure 3.4 Stroke diagrams for inner and outer side buffers

The performance during a collision on a curved track differs significantly from that on a straight track. On a straight track, the buffers engage simultaneously and behave identically, whereas on a curved track, the

engagement is staggered and hence the characteristics are different. This can be seen by comparing the two sets of results (note:- these graphs have different force scales).

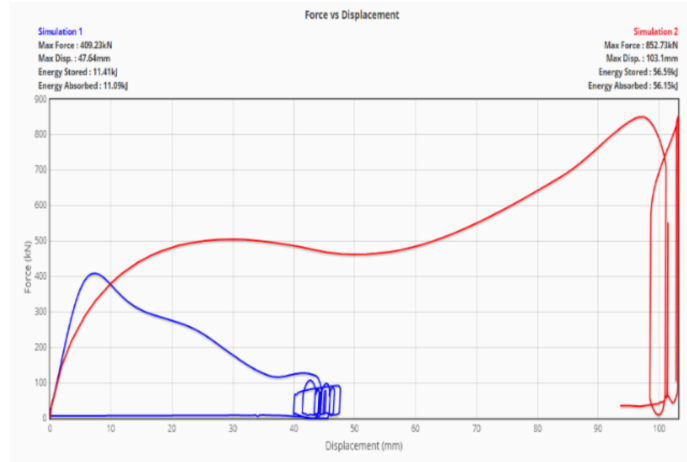
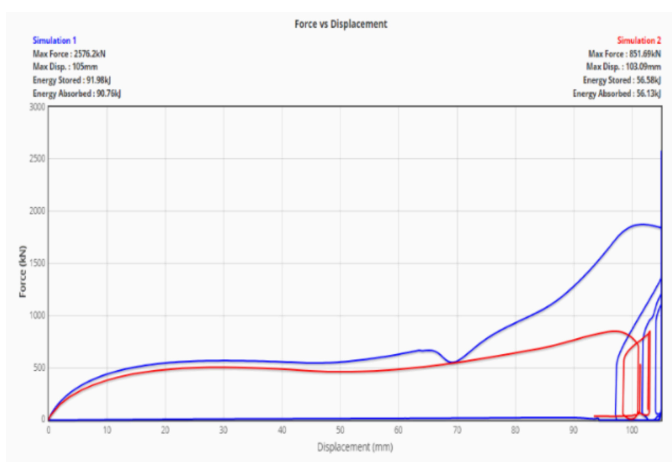

Figure 3.5 Comparison of force-stroke diagrams on curve with those on a straight track.

The graphs show that the side buffer on the inside of the track uses its full stroke, resulting in a 'bottoming out' force of 2576kN. The buffer on the outside of the track only strokes about half its available stroke and generates a much lower force (409kN).

This compared to a force of 853kN on both sides in a straight on collision. The energy stored by the buffers on the curve totaled 103.4kJ compared to 113kJ for a collision on a straight at the same velocity.

Analysis of the wheel loads show that no lifting occurred in this collision, so no derailment is likely, although, significant lateral forces were applied to the outer rail.

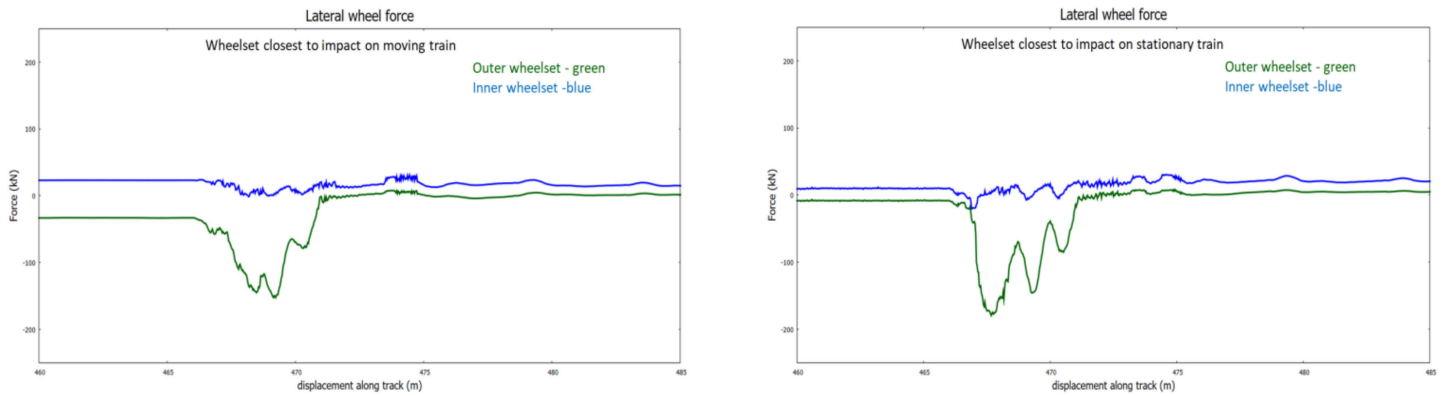

Figure 3.6 The lateral wheel forces on moving and stationary vehicles.

3.3 Passenger Train Impacting on a Curve

The simulation of the passenger train consisted of five vehicles each weighing 37T. The two trains collided at 25km/h on the same 200m radius curve as the freight train. The passenger trains had a crash energy management system designed for an impact a 25km/hr.

The front and rear of the trains were equipped with centre auto-couplers and side anti-climbers. The centre coupler consisted of a 100mm stroke hydraulic coupler shank fitted with a type 10 coupler head and attached to a pivot with a rear mounted deforming tube.

In Figure 3.7, the anti-climbers are displayed semi-transparent because they are user-defined, rather than being sourced from the DigitalTrains™ anti-climber library. When users create their own devices, they are required to input only the essential geometric parameters needed for simulation and animation. User-defined devices are always shown semi-transparent to indicate that their exact geometry is not known. It was assumed that user defined anti-climbers compress telescopically and their deforming characteristic is predetermined.

The intermediate interfaces were coupled with a coupler shank and a 500mm stroke deforming tube.

The coupler shank in this instance was a combined 125mm stroke hydraulic absorber and a 230mm deforming tube.

The performance of the centre couplers is minimally affected by collisions on a curve, although the resulting force is applied at an angle to the vehicle's centreline, generating a yaw moment. An additional yaw moment is applied since the inner anti-climbers engage before the outer anti-climbers.

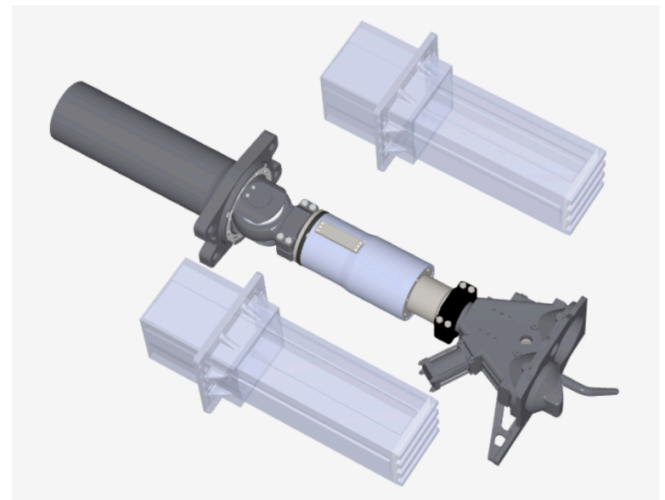

Figure 3.7 Auto Coupler interface geometry



Figure 3.8 Intermediate Coupler interface

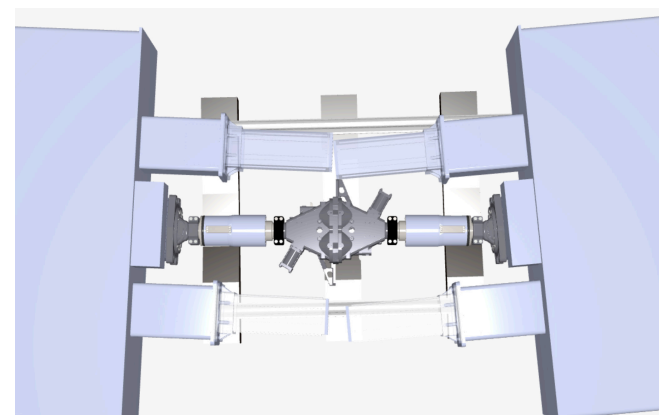

Figure 3.9 Alignment of Anti-Climbers at point of contact

The effect of the anti-climbers not engaging simultaneously can be seen on the Force - deflection diagram at the impact interface.

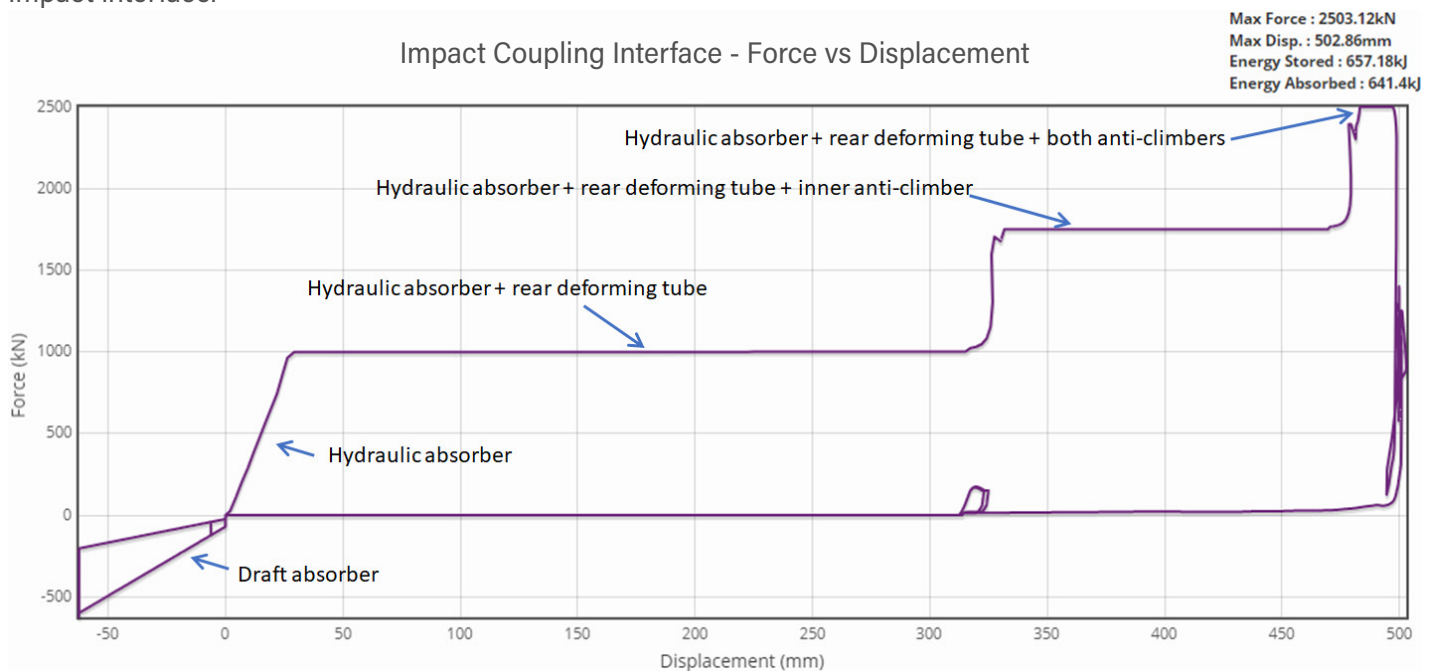

Figure 3.10 Total force deflection diagram at impact interface on 200m radius curve at 25km/h

This compares with the total force deflection on a straight track.

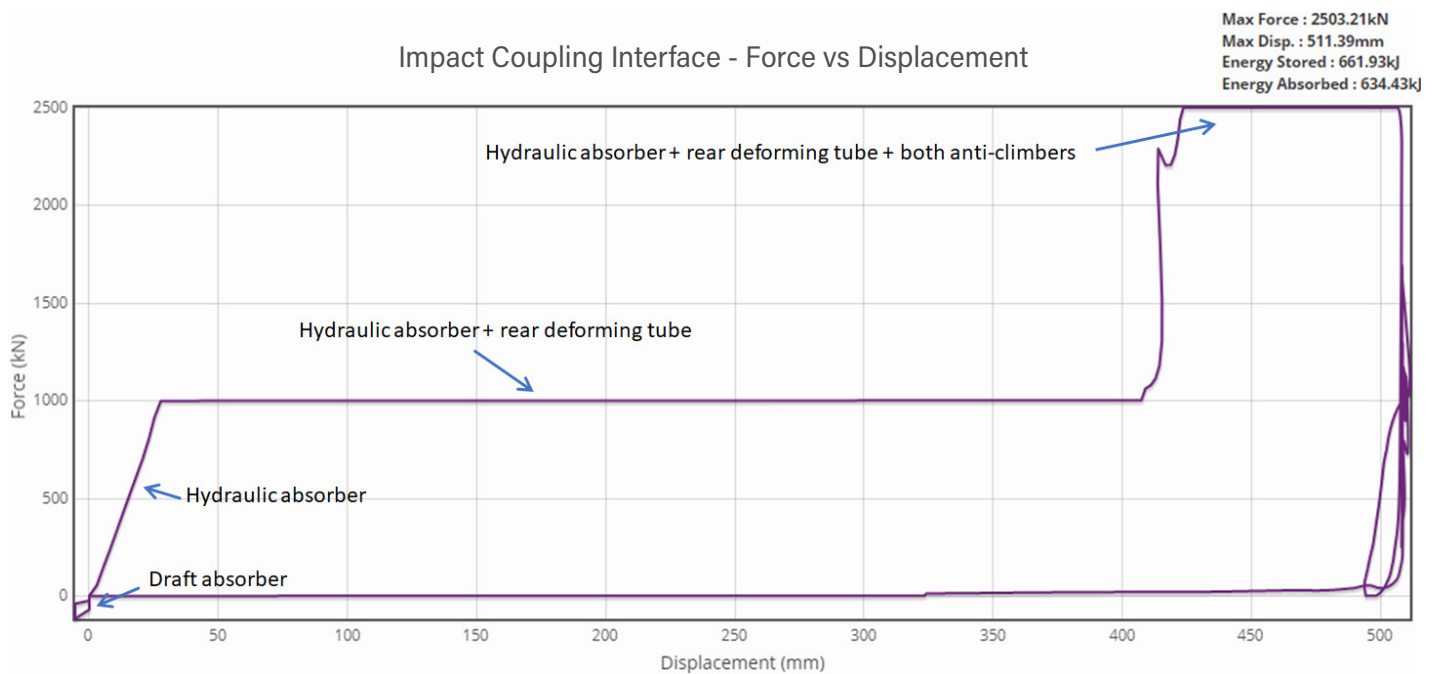

Figure 3.11 Total force deflection diagram at impact interface on 200m radius curve at 25km/h

It can be seen from the diagrams that the sequence of events is different when impacting on a curve. In this instance it did not significantly change the crash energy management of the train, but the effect of impacting on a curve is always worth considering when designing the crash energy management for a train.

On a straight track, it is generally considered advantageous for forces to be applied away from the centre, as this helps prevent the 'snaking' effect sometimes observed in collisions. However, on curves, applying force away from the centre results in lateral loads on the wheels. The lateral loads in this example are shown in Figure 3.11.

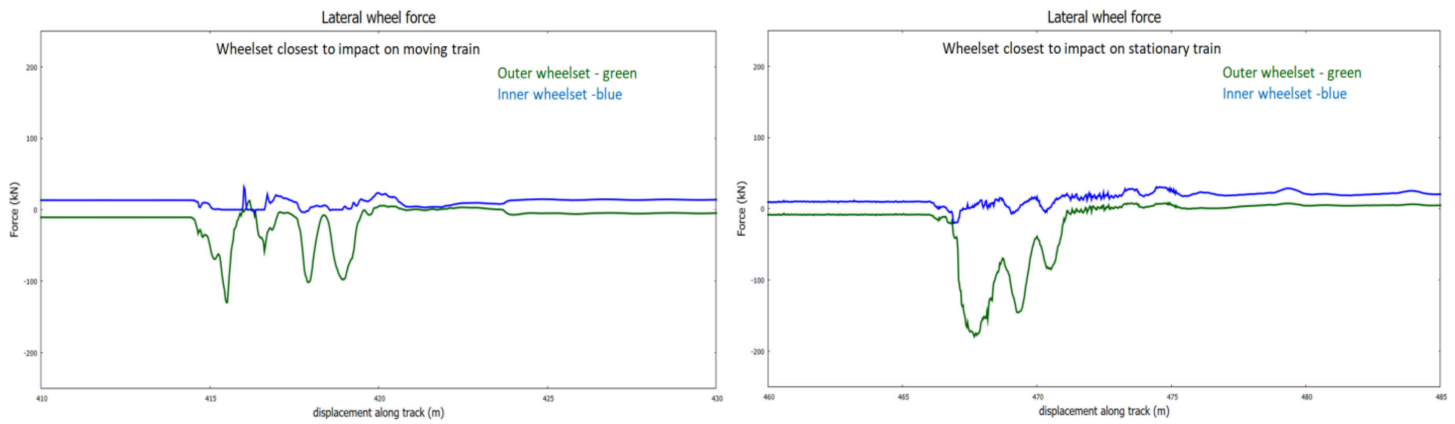

Figure 3.12 Total force deflection diagram at impact interface on 200m radius curve at 25km/h

The magnitudes of the lateral loads are not markedly different from those in the freight train example; however, in this case, the vehicles are significantly lighter. This results in a tendency for the wheelsets to pivot around the contact point of the outer rail flange, leading to lifting of the inner wheel.

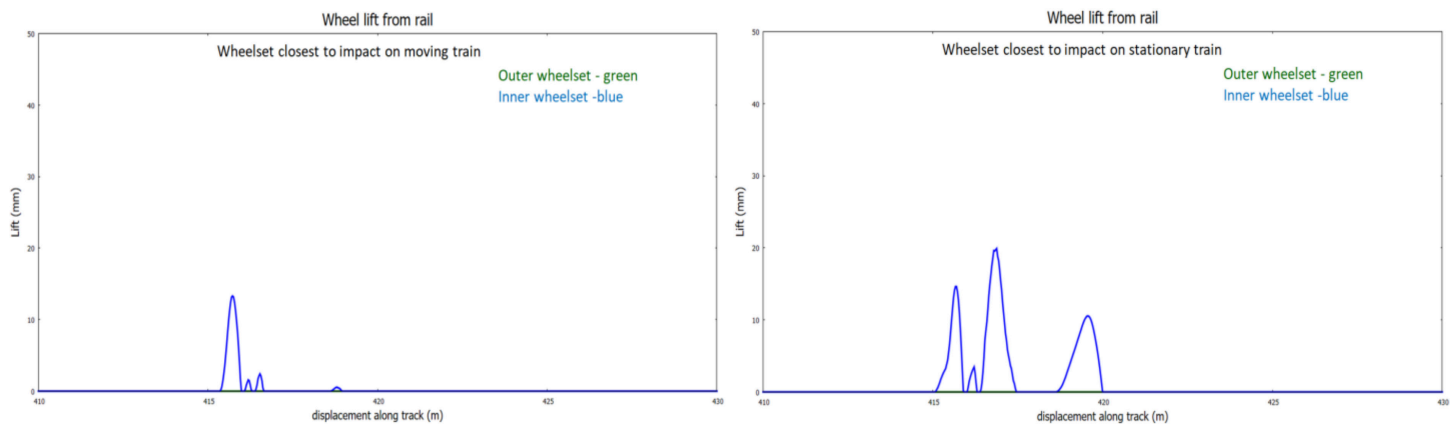

Figure 3.13 Total force deflection diagram at impact interface on 200m radius curve at 25km/h

The two examples in this section were chosen to demonstrate the type of analysis that can be performed with Digital Twins of trains on a platform that also support Digital Twins of track profiles.

4.0 Validation

The Vampire software package was established in the late 1980s, evolving from a set of analytical programmes developed by British Rail Research over previous years. Owing to their unique position, British Rail Research were able to test, validate, and develop their own code through access to specialised test vehicles and tracks, including the test site at Old Dalby.

Tests specifically aimed at validating the non-linear transient program were performed using load-measuring wheelsets. These tests were conducted on various platforms: the experimental Advanced Passenger Train (APT-E) operating at up to 9 degrees of cant deficiency, a long-wheelbase two-axle vehicle (HSFV1) on sharply curved tracks, and a bogie vehicle with adjustable suspension (Laboratory Coach No.1). A final validation exercise for the non-linear transient analysis programme was carried out in 1985, using the Class 56 locomotive. Special shallow lateral track kinks were installed at the Old Dalby test site to stimulate kinematic wheelset response to discrete lateral forcing inputs. It was concluded that the non-linear transient response programme accurately predicted the response of the Class 56 locomotive.

Whilst Vampire has been continuously developed in recent years and has evolved into VampirePro®, the incorporation into DigitalTrains™ still retains the original analytical code developed by British Rail Research.

Integrating Vampire with the hydraulic buffer and coupler algorithms created by Oleo International enables more accurate longitudinal dynamic simulations to be conducted. The algorithms for these components, which are included in DigitalTrains' public libraries of devices and coupling interfaces, have undergone rigorous validation. Specifically, the tests confirming their accuracy were performed in an ISO 17025-approved testing facility. Similarly, all anti-climbers and deforming tubes featured in DigitalTrains' public libraries have been validated against tests performed in an ISO 17025-certified test facility.



5.0 Future Developments

DigitalTrains™ is fully supported and continues to undergo development. In alignment with its stated aim to serve as a Digital Twin environment that treats the railway system as a single entity, it is acknowledged that there are presently gaps in its capabilities. For example, whilst bogies can presently be attached to individual vehicles, there is no provision yet for attaching Jacob bogies that are shared between vehicles. Plans are also in progress to incorporate the modeling of gangways and pantograph's.

Another key objective for DigitalTrains™ is to make Digital Twin technology more accessible and user-friendly. Advances in artificial intelligence (AI) offer promising avenues for enhanced user interaction.

Work is currently underway to develop a chatbot that assists users in navigating the functionalities of DigitalTrains™. The longer-term objective is to employ AI in facilitating model creation, running simulations, and highlighting significant results.

DigitalTrains™ is not intended to compete with good, well established software packages, but to be complementary to them. Our aim is to enable models to be imported from other software platforms.



